

DOOSAN

Wheel Loaders |
DL280-5



Maximum power: 172 HP
Operating weight: 15541 kg
Bucket capacity: 2.8 m³



Doosan Group – Building your tomorrow today

▣ Be part of the great Doosan family

The Doosan Group - founded in 1896 and headquartered in Seoul, South Korea - is one of the fastest-growing companies in the world:

- With more than 37,500 employees in 38 countries, we are a major player in a variety of industries worldwide.
- A global leader in the Infrastructure Support Business (ISB), with 56 subsidiaries and 3,700 distributors worldwide.
- Dramatic growth over the past two decades, with an annual Doosan Group revenue rising from €2.4 billion in 1998 to €12.8 billion in 2016.

▣ Doosan Group – a top player worldwide



Doosan Infracore

- Among the world's Top 5 manufacturers of construction equipment



Doosan Bobcat

- A leading company in the design, manufacture, marketing, distribution and service of small equipment and attachments for construction, agriculture, and landscaping
- Leading position in the global compact equipment market
- N° 1 in North America for SSL, CTL and MEX



Doosan Heavy Industries & Construction

- World N° 1 in desalination plant construction
- World N° 1 in heat recovery steam generator market
- World N° 1 in mould & tool steel
- World N° 3 in crankshafts



Doosan Engineering & Construction

- A pioneering leader in construction of residential and public buildings, civil works and industrial facilities.
- World N° 1 chemical process equipment products



▣ Doosan Infracore Construction Equipment

Creating construction equipment for over 40 years

For over 40 years, we've been building a global production and business network to become one of the world's foremost construction equipment manufacturers.

A solid partner, close to you

A truly global player in every respect, we have large-scale factories, sales subsidiaries and dealers all over the world.



Doosan facilities in Europe

From machine manufacturer... to full solution provider

To ensure the highest trade-in and residual values, our parts and service support professionals maintain the performance, productivity and reliability that you expect of our products throughout their lifetime.

Ask your dealer for a full range of services designed especially for you!

As your local specialist, your dealer ensures that you receive the maximum benefit from our integrated package. Plan ahead to ensure the success of your equipment!



Doosan approved attachments



Genuine parts



Extension of warranty



Financial solutions



Maintenance contract



Telematics



Monitoring systems



Dealer Locator

Europe

Select a country

City, Country

Search

Dealer locator

Advanced Services

- Articulated dump trucks
- Mini excavators
- Crawler Excavators
- Wheeled Excavators
- Wheel Loaders



Experience the Doosan product range!



Articulated Dump Trucks



Wheel Loaders



Wheeled Excavators



Mini Excavators



Crawler Excavators

Raise productivity, fuel-efficiency & profits

► Productivity

Thanks to their robust design and the use of high-quality components, the Doosan wheel loaders deliver very high performance – ensuring you the best productivity and reliability.

⊙ **Z-bar:** "Z" kinematic delivers a huge break-out force, especially for heavy materials, and a large dump angle for unloading sticky materials efficiently.

⊙ **Worktools:** Wide range of heavy-duty attachments to answer all of your needs.

⊙ **Linkage:** Direct mount for the best performance or via a hydraulic quick coupler to change & lock work tools quickly and safely from inside the cab.

⊙ **Simplicity of operation:** "Lift arm raise kick-out" and "return to dig" bucket – Automated functions operated electronically from inside the cab.

⊙ **Versatility:** 3rd valve (standard) increases the versatility of your investment.

⊙ **Load Isolation System:** Ride control (standard) reduces pitch effect and vibrations to provide the most comfort.

⊙ **Automatic differential lock:** Limited slip or hydraulic lock – the machine delivers all of its performance, while preserving fuel consumption and reducing wear on the tyres.

⊙ **Hydraulic system:** Load sensing closed centre system provides the operator with precision & smoothness while reducing fuel consumption.



Total cost of ownership ▲

Minimising your operating costs is at the heart of the Doosan wheel loader's design, every day.

⊙ **Safety:** Always a critical factor for your company and your employees – so, these machines feature large platforms, hand-rails, and 2 emergency exits, with maintenance performed from the ground.

⊙ **Spacious cab:** Operator enjoys comfortable driving, with many ergonomic features as standard.

⊙ **Power:** Exceptionally powerful, with high torque at low revs, the Stage IV compliant Doosan engines do not need a Diesel Particulate Filter (DPF) and associated regeneration system, so they deliver greater fuel efficiency.



DOOSAN CONNECT

⊙ **Telematics:** Monitor your fleet online. As standard, Doosan Connect system with dual mode (satellite, GSM). Check productivity, fuel consumption, system warnings, maintenance status, etc.

⊙ **Efficient fuel management:** The Doosan DLo6 engine provides 3 different working modes. The right set-up enables great savings on fuel consumption.

⊙ **Cooling performances:** Cooling compartment separated from the engine compartment to prevent warm and dusty air from entering and to allow better control of air intake. Automatically reversing fan as standard.

⊙ **Full fenders:** As standard, to keep your machine clean and your operators even safer.

⊙ **Serviceability:** Spacious access to main components allows quick and easy daily maintenance.

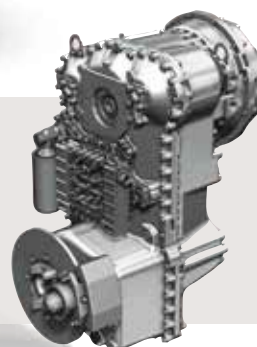

Powertrain: 4 gears to boost acceleration and performance, especially on slopes. The gear ratios are optimized, and smooth; shock-free shifts contribute to the high overall level of operator comfort.



Top performance and fuel efficiency



Strength and intelligence – a winning combination!

Exceptional power – combined with the finest workmanship – results in a machine that performs at the highest level. The DL280-5 enhances your output from every angle:

- Impressive breakout force and high traction make penetration easy and allow you to tackle the hardest materials
- Powerful hydraulic system makes work quick and efficient
- New Doosan DLo6 engine with SCR technology provides the power you need while meeting Stage IV environmental regulations

The combination of these features gives Doosan wheel loaders excellent penetration power, ensuring optimum bucket load in each cycle.



New engine – lower emissions / higher torque

The DL280-5 is equipped with a Doosan engine. Famous for excellent fuel efficiency, reliability and long service life, it combines exceptional power output and high torque at low revs. Common-rail fuel injection is combined with a wastegate turbocharger for faster machine response.

Selective Catalytic Reduction (SCR) technology, combined with a Diesel Oxidation Catalyst (DOC), ensures compliance with Stage IV environmental regulations. As there is no need for a particulate filter, there is no need for regeneration.



Developed for heavy-duty applications

Heavy-duty axles are available to bring possibility to use solid, agricultural or other L5 tyres in hard applications. In combination with the rigid reinforced Z-bar kinematic and the proper attachment, you have your long-lasting, durable solution.

Save fuel, save money

To improve your fuel efficiency, the auto shut-down reduces the engine's idle time to prevent over-consumption and needless operating hours. You can easily set the auto shut-down (to stop the engine after 3 to 60 minutes) via the LCD display.

ECO gauge

Shows the average fuel efficiency for 1 minute of operation.

Transmission

The Doosan ZF transmission has 4 gears to boost acceleration performance. The gear ratios are optimised and smooth, and shock-free shifts contribute to the high overall level of operator comfort. Traction force is also maximized.

Together, these qualities enable high working speed in all conditions. The transmission has 3 operating modes:

- Manual
- Automatic (working, 1st to 4th gear)
- Automatic (travelling, 2nd to 4th gear)

An automatic kick-down improves the machine's penetration into the pile.

Load sensing hydraulic closed centre system

This system provides maximum hydraulic performance, without producing excess capacity, thus saving fuel and extending the lifetime and reliability of vital components (such as the pumps and the main control valves).



The Doosan DL06 turbocharged diesel engine fully complies with Stage IV emissions limits. 6 cylinders of 5.9 l displacement make the machine nimble and extremely powerful. Common rail fuel injection for more efficient combustion and economical operation under any working conditions.

Operating in comfort

▣ Comfort – why do without?

The productivity of your wheel loader is directly linked to the operator's performance. That's why Doosan has placed comfort at the very centre of its design priorities for the DL280-5.

More room, better visibility, a high comfortable seat, and plenty of storage space make it easy to work for hours without fatigue or discomfort. And there's no need to pay extra for the options you want – most of them are standard features on this loader!

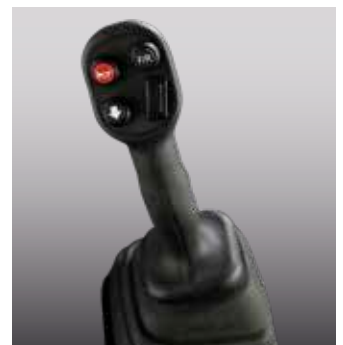
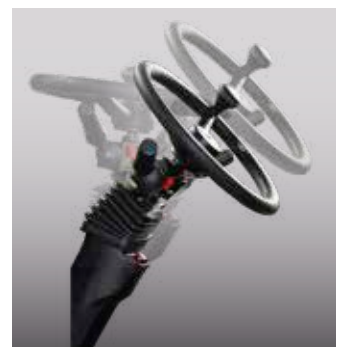

Operator environment

A modern and attractive work space offers generous head room, and seat movement provides lots of leg room. Interior materials are selected for their high quality and easy cleaning. In addition, your belongings are right at hand, thanks to several storage boxes throughout the cab.

Comfortable automatic lift arm

Save time and reduce the number of operations with the “lift arm raise kick-out” and “return to dig” system. These functions are operated electronically from inside the cab.

High-comfort air suspension seat

With vertical and horizontal suspension, the ultra-comfortable, heated and fully adjustable Grammer seat is featured as standard, giving you the feeling of being comfortably installed in your own sofa.

Load Isolation System

This standard feature provides a smooth ride over rough ground, operator comfort, and reduced cycle times due to improved vehicle stability in movement. Higher productivity and better fuel efficiency while performing load & carry applications. Speed for automatic activation is adjustable by the operator.

Accurate & smooth joystick steering

Keep your concentration and reduce strain with the comfortable joystick steering integrated on the armrest. Drive your machine easily, especially in repetitive tasks and tight spaces.

Automatic air conditioning

Day and night, whatever the weather, set your preferred temperature for the best working conditions. Fully automatic climate control system adjusts air temperature and fan speed to maintain your ideal climate setting.

Adjustable steering column

Enhance your driving comfort, and work without fatigue, by easily adjusting the steering column's tilt and telescopic movements to fit your preferred position.

Colour LCD monitor panel

The 5.7" LCD panel is suitable for day and night work. The user-friendly monitor has two customizable screen displays (per operator's preference), giving full access to machine settings and maintenance data. Any abnormality is clearly displayed on the screen, allowing you to work safely and confidently with an accurate overview of all conditions.



DOOSAN

DOOSAN

Large spacious cab equipped with wide windshield gives you full control and great visibility even into bottom areas of the front frame of the machine. Good overview of the bucket, tyres and loading area, and highest comfort for operator, are essential for high productivity.

Expert control with maximum safety

▣ Safe operation in all simplicity

Power alone is not enough – for maximum efficiency, it needs to be matched by precise control. Our unique range of features allows every operator to get the most out of these impressive machines.

Safety is crucial to your company and your employees – so, these machines feature large platforms, hand-rails, and 2 emergency exits, with maintenance performed from the ground.



Rear view camera

A camera provides a clear view of what's happening behind the machine for added safety and peace of mind. The full colour display screen in the cab shows the operator what the camera sees. The panoramic view shows trucks coming up behind the loader or people on the ground, and some indicators provide a good perception of distances.

External mirrors

The external mirrors are heated to ensure visibility and prevent accidents in cold weather.

Full fenders and mud guards

To keep them clean and avoid mud splashing on the windows or accidents on slippery steps, Doosan's wheel loaders are standard equipped with full fenders and mud guards.

Cab

To ensure a healthy work environment, the cab air is filtered twice to eliminate all particles larger than 2 microns. Plus, the cab satisfies ROPS/FOPS regulations – a wide emergency exit (located on the right side) provides fast, easy evacuation in a critical situation.

Safe maintenance

Checking all the gauges daily takes place from the ground, so that maintenance is quick and safe for everyone.

The Doosan automatic greasing system reduces working time and increases operating comfort.

Safe access

To facilitate access and mobility on the machine, multiple hand-rails ensure that the operator always has a firm support to hold on to.

Driving assistance

- Automatic transmission with smooth shift transition
- Automatic transmission kick-down
- Automatic Hydraulic Differential Lock (HDL)
- Automatic Lift-arm Suspension (LIS)
- Automatic kick-out function on lift arm
- Automatic return to dig position
- Automatic reversing fan
- Automatic greasing system



Joystick control



Fingertip levers

Ergonomic controls: All controls are placed within the operator's easy reach. Clearly positioned for comfortable access, and grouped by function, they enable safe, confident operation. The bucket is controlled by using a convenient joystick or with fingertip levers. Both include an FNR reversing switch and kick-down function.

Reliability, the habit of a lifetime

▣ Dependable performance for low lifetime cost

Doosan has been building heavy construction equipment for 40 years. This extensive experience is reflected in the superior design and development of our wheel loaders and by an extensive logistics network. Plus, our standard machines include a wide range of features at no extra cost (other manufacturers offer these only as options).



Designed to last

We pay the closest attention to the design and manufacture of structural components. Finite Element Analysis is used to ensure an extended lifetime for main structures such as the chassis, joints and lift arm. Then, after modelling, they are subjected to intensive laboratory and field testing in extreme conditions. Ongoing statistical analysis is used to continually increase reliability.

Durable steel parts

Rear parts – such as the radiator grille, engine bonnet and fenders – are made of solid steel. They're also designed for easy repair, reducing the need to replace them if they are damaged.

Articulation hinges

The robust hinges feature a clean and solid design with 40° articulation angle.

Exhaust

The inner exhaust pipe sucks air out of the engine compartment through an outer pipe – this "chimney" effect provides constant air circulation and prevents deposits of flammable material on hot parts.

Auto-lube

The DL280-5 can be equipped with an automatic central greasing system: 'Auto-lube' protects components for longer machine lifetime.

ORFS (O-Ring Face Seal)

All hydraulic lines, even the low pressure circuits, are sealed with ORFS couplings to prevent leaks.

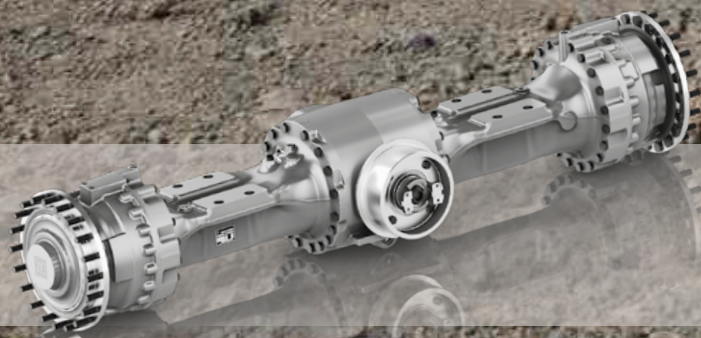

Limited slip differentials: Limited slip differentials at the front and rear automatically ensure maximum traction and easy driving over soft and muddy ground with no need for a manual differential lock. They also reduce the risk of skidding and prevent excessive tyre wear. An optional hydraulic differential-lock can be activated automatically if one tyre starts to slip. The outboard disc brakes enable easy service without dismantling the axles.

Simple maintenance with maximum uptime

▣ Excellent service accessibility

Short maintenance operations at long intervals mean you can depend on your equipment being available on-site when it's needed. Our machines are designed for simple routine maintenance, while skilled Doosan technicians are available to provide extra support when you need it. To get the most out of your machine, you can choose the package you need from a broad range of service agreements. Uptime, productivity and residual value are all maximised, making these wheel loaders an economical and rewarding choice.

Building further on the success of the Stage IIIB engines, the Doosan DLo8 Stage IV engine does not need a DPF filter to meet the Stage IV emissions requirements. Which means no maintenance required – resulting in more uptime!



Maintenance access made simple

- The front and rear of the radiator – which is made of aluminium for the highest pressure resistance and a long lifetime – are easily accessible
- A battery cut-off switch makes it easy to disconnect the battery during long-term storage
- The hour meter display can be easily checked without turning the engine on

Triple-element air filter

The forced-air cleaner removes 99% of particles and is backed up by a turbo pre-filter. Cleaning and cartridge replacement are only needed at long intervals.

Engine

The Doosan EMS (Engine Management System) uses a CAN (Controller Area Network) to provide a constant flow of operating information as well as diagnostic and ECU programming functions.

SCR Tank

Connected to the ECU, sensors in the tank detect low levels of AdBlue® and any system malfunction.

Global Doosan network

With a network of Doosan dealers & Parts Distribution Centres worldwide, your Doosan wheel loader can be serviced & maintained wherever you are. Our service centre in the heart of Europe has more than 40,000 parts in stock to supply you with top-quality components as quickly as possible.

Full solution provider

- The Doosan Telematic system is available as standard – offering you all of the features for reading out vehicle operating & production parameters remotely, and providing you with total ease-of-mind
- Protection+: an extended warranty covering parts, travel and service (check with your local dealer)
- Maintenance contract: your dealer will support you with routine service at regular intervals
- Genuine parts: manufactured and tested to ensure they always meet the same high quality standards as the original components

Wide fin pitch radiator

The wide fin pitch protects the radiator from becoming clogged in heavy-duty, agricultural or waste recycling applications. Keeps the cooling system performing constantly and minimizes machine downtime. Easy access is ensured by upper hinge grille opening.



Well organized and easily accessible connections in the articulation hinge.



Battery cut-off switch



Centrifugal pre-cleaner
Top Spin™ Donaldson®



Wide fin pitch radiator

Technical specifications

Engine

Doosan DLo6 Stage IV (Tier 4 final) compliant diesel engine fully meets the latest emissions regulations. Common rail high pressure injection ensures very good fuel efficiency. Electronic engine controls optimize machine performance and manage the catalytic operations by a Diesel Oxidation Catalyst (DOC) and a Selective Catalytic Reduction (SCR).

DL280-5	
Model	Doosan DLo6
Regulation compliant	Stage IV
No. of cylinders	6
Nominal power - gross (SAE J1995)	172 hp (128 kW) at 1800 rpm
Maximum torque - gross	840 Nm at 1400 rpm
Idle (low - high)	800 - 2100 rpm
Displacement	5.9 litres
Bore × stroke	100 mm × 125 mm
Starter	24 V - 6 kW
Batteries - alternator	2 × 12 V, 100 Ah - 24 V, 80 A
Air filter	Centrifugal pre-cleaner Top Spin™ Donaldson® with 2-stage dry filter. Cooling package with automatic reversing fan to facilitate radiator cleaning.
Cooling	Automatic rotation speed adjustment according to temperature conditions.

Transmission

4 gears to boost acceleration performance, especially on slopes. The gear ratios are optimized, and smooth; shock-free shifts contribute to the high overall level of operator comfort. Maintenance-free torque converter ensures good freewheeling attitude.

DL280-5	
Type	4 speed automatic Power-shift
Speeds - Forward 1-2-3-4	6.3 - 12.4 - 23.1 - 35.5 km/h
Speeds - Reverse 1-2	6.6 - 13.1 - 24.2 km/h
Maximum traction	12 t
Maximum gradeability	58% / 38°

Axles

Front & rear axles manufactured by ZF with outboard planetary reduction gears. The front and the rear are equipped with Limited Slip Differential (LSD), which means the machine has the optimum traction in all conditions. 12 t traction power allows operation on slopes of 58%.

DL280-5	
LSD lock ratio	30% (Front & Rear)
HDL lock ratio	100% (Front)
Oscillation angle	+/- 12°
Tyre size - standard	20.5 R25 (L3)

Hydraulic system

DL280-5	
Type	Load sensing - closed centre hydraulic system
Main pump	Variable displacement axial piston pump
Maximum flow	210 l/min
Maximum pressure	265 bar
Pilot system	Automatic functions for positioning the bucket ready to dig and a function for stopping the lift arm at the desired height, and low position adjusted manually by switch, are standard.
Filtration	In the oil return to the tank, the fibre glass filter has a filtering capability of 10 micron.

Lift arm

Z-kinematics with simple lifting piston system designed for heavy-duty applications. 145 kN breakout force combines with a bucket angle that is maintained throughout the range of movement. Bucket angles are optimised in the travelling position and at ground level. Load Isolation System (LIS) is fitted as standard for improved operator comfort and greater machine output and lifetime.

Load cycle

DL280-5	
Lift arm - up	6.3 s
Lift arm - down	3.2 s
Bucket - crowd	2.1 s
Bucket - dump	1.3 s

Hydraulic cylinders

DL280-5		
	Quantity	Bore × rod diameter × stroke (mm)
Lift	2	135 × 80 × 790
Bucket	1	160 × 95 × 510

Brakes

Dual multi-disc circuit with sintered metal discs for extended service life. Braking system activated by a pump and accumulator circuits. Spring-applied, hydraulically released parking brake is mounted on the transmission shaft and accumulator circuits and is electronically activated. Brake type: spring-applied / hydraulically released. Brake pump with variable displacement axial pistons provide 38 l/min. Operator can activate/deactivate the Intelligent Clutch Cut Off on the brake pedal from a switch and can adjust the sensor proximity with the same switch.

DL280-5	
Braking distance	8.4 m at 33 km/h
Number of disc brakes per wheel (front / rear)	16 / 14
Accumulators	0.75 l - 30 bar

➤ Cab

Safety compliance with Roll Over Protection System (ROPS) and Falling Object Protective Structure (FOPS) requirements.
Spacious modular cab with excellent all-round visibility and ample storage space. Good overview of the bucket, tyres and loading area thanks to wide windows. Pushbutton controlled air conditioning and heating with air recirculation function. Double cab air filter installed in the cab with extra protection for the operator in dusty or polluted environments. Viscous suspension mount for maximum comfort. Adjustable high-quality heated seat with air suspension, arm rests and height and tilt adjustable steering column. All operating information clearly displayed in front of the operator. Control functions are centralized on a console on the right.

DL280-5	
Safety standards	ROPS ISO 3471:2008 FOPS ISO 3449
Door	1
Emergency exits	2

▶ Noise emissions

DL280-5	
A weighted emission sound pressure level at the operator position (ISO 6396)	Declared: 72 dB(A) Measured: 71 dB(A)
A weighted emission sound power level at external position (ISO 6395)	Declared: 103 dB(A) Measured: 101 dB(A)

➤ Fluid capacities

DL280-5	
Fuel tank	235 l
Urea (AdBlue®) tank	32 l
Cooling system	32 l
Engine oil	24.5 l
Front axle	35 l
Rear axle	35 l
Hydraulic system	120 l
Transmission oil	37 l

➤ Steering system

DL280-5	
Type	Load sensing with amplification stage and priority valve
Steering angle	40°
Oil flow	210 l/min
Operating pressure	195 bar
Steering cylinders (2)	Emergency steering system with electric motor-driven hydraulic pump
Bore × rod diameter × stroke	70 × 45 × 425

➤ Pressure settings

DL280-5	
Working (pump cut-off)	265 ± 5 bar
Steering relief – LS port side	175 ± 10 bar
Steering relief – steering pump side	195 ± 10 bar
Pilot control	32 ± 2 bar
Brake accumulator charging	100 ~ 160 bar
Service brake	60 ± 3 bar
Fan motor	160 ± 10 bar
Parking brake release	120 ± 5 bar
Transmission selection pressure	16 ± 1 bar



Technical specifications

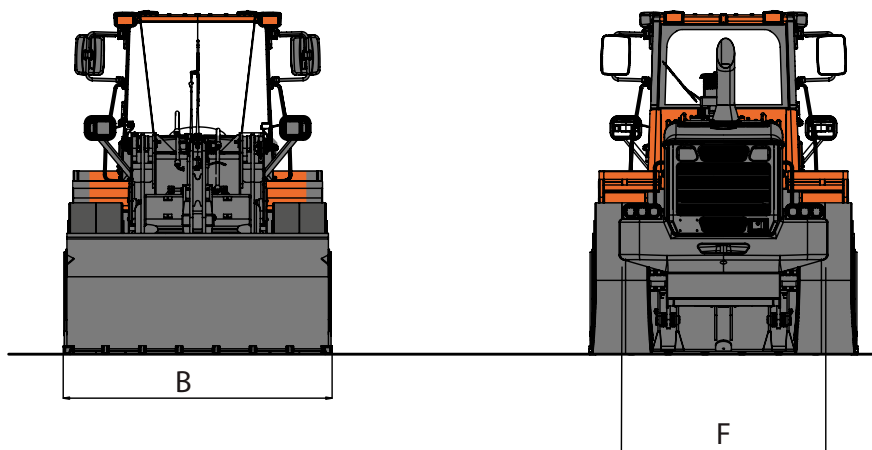
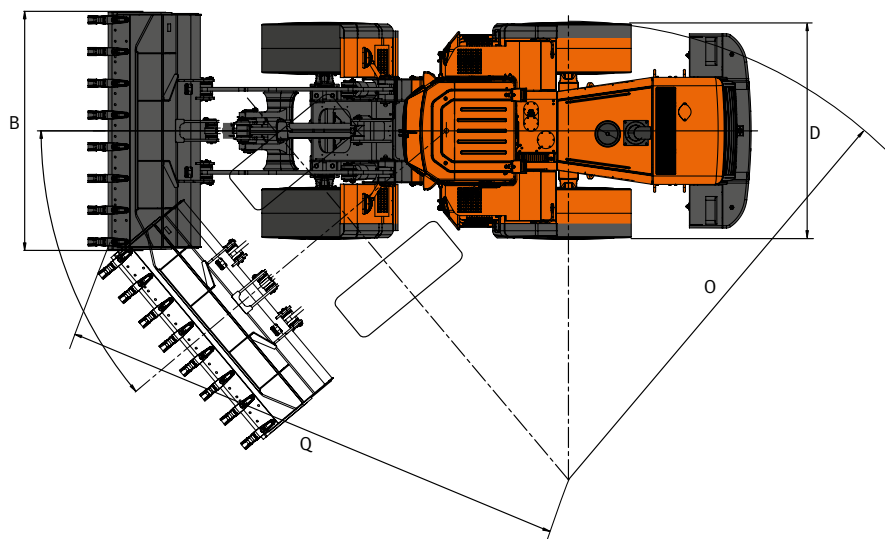
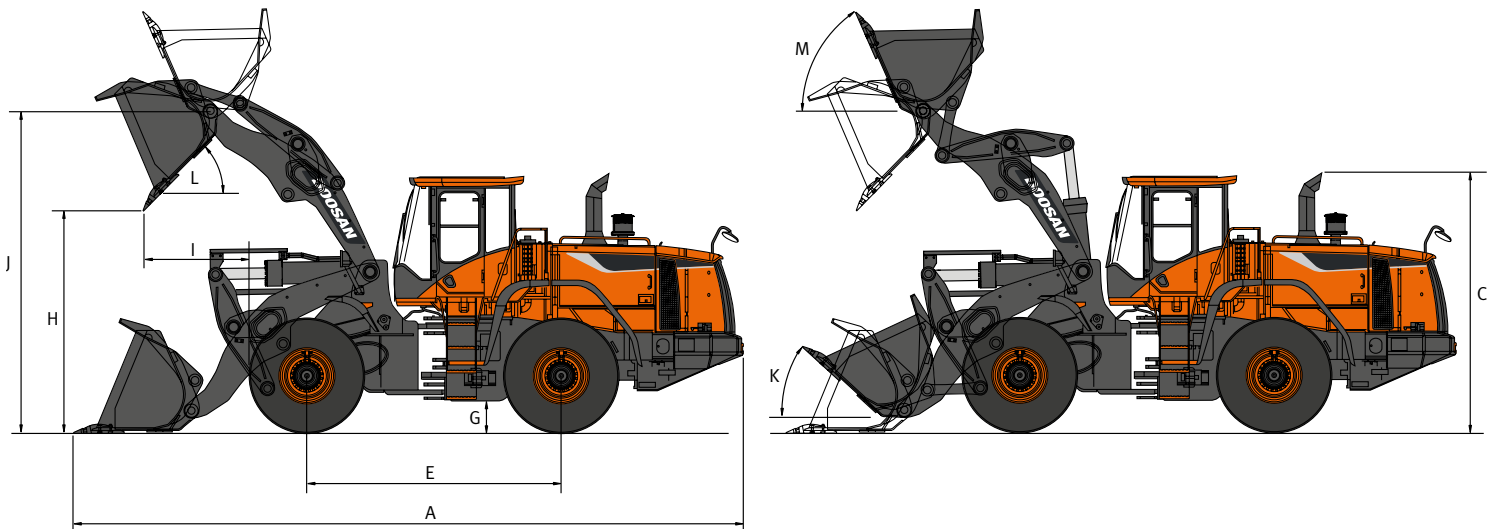

➤ Dimensions and operational data

DL280-5 – Pin-on		General purpose				
Configuration		Standard Z-bar		High Lift		
		Teeth	Cutting edge	Teeth	Cutting edge	
	Capacity heaped ISO/SAE	m ³	2.7	2.8	2.7	2.8
B	Bucket width	mm	2740	2740	2740	2740
	Breakout force	kN	145	135	136	127
	Static tipping load (straight)	kg	12449	12014	10218	10103
	Static tipping load (at full turn)	kg	10993	10609	9023	8921
H	Dump height (at 45° – fully raised)*	mm	2745	2802	3170	3245
I	Dump reach (at 45° – fully raised)*	mm	1220	1150	1240	1170
	Dump height (at max. dump) – (at max. reach)*	mm	1560	1525	585	685
	Dump reach (at max. dump) – (at max. reach)*	mm	590	690	1855	1820
	Digging depth	mm	120	115	210	200
J	Height at bucket pivot point	mm	3940	3940	4360	4360
	Max. tilt angle in carry position	°	48	48	47	47
M	Max. tilt angle fully raised	°	62	62	58	58
K	Max. tilt angle on ground	°	42	42	40	40
	Max. tilt angle at max. reach	°	60	60	57	57
	Max. dump angle at max. reach	°	66	66	68	68
	Max. dump angle on ground	°	66	66	76	76
L	Max. dump angle fully raised	°	46	46	45	45
O	External radius at tyre side	mm	5420	5420	5475	5475
Q	External radius at bucket edge	mm	6115	6085	6335	6300
E	Wheel base	mm	3010	3010	3010	3010
D	Width at tyres	mm	2570	2570	2570	2570
F	Tread	mm	2040	2040	2040	2040
G	Ground clearance (at 10° osc.)	mm	389	389	389	389
A	Overall length	mm	7800	7700	7800	7700
C	Overall height	mm	3310	3310	3310	3310
	Operating weight	kg	15682	15541	15841	15952

(*): measured to the tip of the bucket teeth or bolt-on edge. Tyre size 20.5 R25 (L3)



Attachments

▣ A Doosan attachment for optimum performance in each activity

Robust construction, excellent penetration, covering several types of applications from light- up to severe-duty. These new Doosan loader attachments are designed and manufactured in Europe to meet local requirements and standards. A large range of attachments guarantees versatility and efficiency all the way. Each bucket is designed for a specific machine model to fit its key kinematic parameters perfectly. Critical bucket positions are optimised to improve digging and dumping. The Doosan attachment concept stands for high quality, perfect fit and excellent operational capabilities.



General purpose buckets

General purpose buckets provide good all-round performance for stockpiling and material-handling operations. With its sloped bottom design for optimum bucket filling capabilities and load retention, this is the perfect bucket for day-to-day material handling. It can be equipped with optional teeth, shrouds and cutting edge, depending on the customer's requirements.



Heavy-duty buckets

Heavy-duty bucket suitable for a range of applications that require a robust construction (such as sand handling or occasional severe loading). Parts subjected to high stress – such as the edge, sidebars and corner protections – are made of hardened steel. Optional teeth, shrouds and reversible cutting edge allow you to tailor the bucket to the customer's needs.



Light material buckets

When you need to move large amounts of light material, this bucket is the most profitable and rewarding choice. Its convex sides allow high capacity and avoid material spilling. Comes standard with a bolted reversible cutting edge.



High dump bucket

The high dump bucket is suitable for light material handling applications. This bucket improves the unload height and increases the versatility of the wheel loader. Its convex sides allow high capacity and avoid material spilling. Comes standard with a bolted reversible cutting edge.



Pallet forks

For loading and unloading different types of pallets as well as normal forklift operations.



Quick-coupler

Particularly advantageous when the machine has a wide variety of jobs to carry out, this hydraulic quick-coupler enables a variety of attachments to be changed quickly and safely.

➤ Bucket selection chart DL280-5

Lift arm	Bucket	Type	m ³	1.5	1.6	1.7	1.8	1.9	2.0	2.1	2.2
Standard lift arm	General purpose	Teeth	2.7			3.1 m ³				2.6 m ³	
		Cutting edge	2.8			3.2 m ³					
High lift arm	General purpose	Teeth	2.7			2.9 m ³				2.4 m ³	
		Cutting edge	2.8		3.0 m ³					2.5 m ³	

Compliant with ISO 14397-1 (2007). The filling factor depends on the type of material, the working conditions and the experience of the operator.

Bucket filling factor 

➤ Density of operating materials

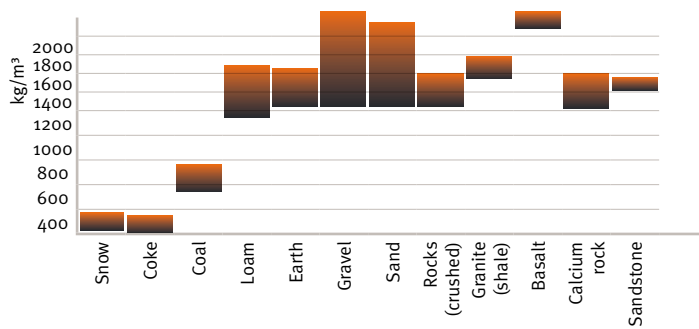

The specific weight of the material largely depends on the level of humidity, the degree of compaction, composition, etc.



Standard and optional equipment

Performances

DL280-5

Doosan, Stage IV compliant, SCR, EGR	●
No DPF	●
Engine power mode selector switch (Standard / Economy & Power mode)	●
Power-up pedal function by full stroke of acceleration	●
Auto shut-off engine	●
Fuel heater	○
Transmission clutch cut-off via the brake pedal	●
Transmission mode selector switch	●
(Manual / Auto 1 ↔ 4 / Auto 2 ↔ 4 with kick-down)	●
Hydraulic load sensing system, variable displacement pump	●
Limited slip differentials on front and rear axles	●
Automatic differentials hydraulic lock on front axle	○
Heavy-duty axles	○
Counterweight	●
Heavy-duty Z bar lifting system	●
High lift loader	○
Quick coupler	○
Wide range of buckets	○

Comfort

Load isolation system (LIS)	●
Automatic lift arm kick-out	●
Automatic return to dig	●
Levelling function	●
3rd hydraulic function	●
Automatic air conditioning with electronic climate control	●
Grammer air-suspension seat with safety belt 2 points	●
Grammer air-suspension seat with safety belt 3 points	○
Mono control lever with FNR switch	●
Fingertip Control	○
Adjustable steering column (tiltable & telescopic)	●
Tinted safety glass	●
Left sliding window	●
Right opening window (180°)	●
Floor mat	●
Multiple storage compartments	●
Cup holder	●
Loudspeakers and connections for radio	●
Lift arm float kick-out	●
Alternator 24 V / 80 A	●
Dashboard monitoring with LCD display (dials, gauges and lamps)	●
Interior cab light	●
Cigarette lighter and 12 & 24 Volt power sockets	●
Weighing system	○

Safety

Emergency steering pump driven by electric motor	●
Full fenders	●
ROPS cab (SAE J 394, SAE 1040, ISO 3471)	●
FOPS cab (SAE J 231, ISO 3449)	●
Double filtered air cab	●
Right opening window (emergency exit)	●
Front and rear wiper and washer	●
Retractable roller sunblind	●
Road lights: low and high beam, tail indicators, stop, reversing lights	●
Work lights: 2 halogen at the front and 4 at the rear (6 × 70 W)	○
Work lights: 2 LED at the front and 4 at the rear (6 × 70 W)	●
Reverse travel alarm	●
Rotating beacon	●
Horn	●
Heated external mirrors	●
Interior rear view mirrors	●
Anti-slip steps & platforms	●
Hand rails around the cab roof & additional platforms on front frame	●
Starting safety system	●
Engine exhaust brake	●
Dual brake circuits with accumulator	●
Dual service brake pedals	●
Electric parking brake on the transmission, spring-applied hydraulic release	●
Wheel chocks	●

Other

Bottom protection plates	●
Lifting hooks	●
Articulation lock in the transport position	●
Towing hitch	●
Tyres 20.5 R25 (L3)	●
Tyres 20.5 R25 (L2)	○
Tyres 20.5 R25 (L5)	○

Maintenance

DL280-5

Automatic lubrication system	○
Hydraulic reversing engine fan	●
Doosan Connect Telematic system	●
Self-diagnosis system & monitoring indicator by the dashboard, plus electronic plug for fast adjustment	●
Fast couplers for hydraulic check	●
External drains for engine oil and coolant changes	●
Biodegradable oil	○
3-years warranty	○
Protection+ warranty	○

Standard: ●
Optional: ○



Joystick with thumb wheel and F/R



Fingertip control



High lift arm

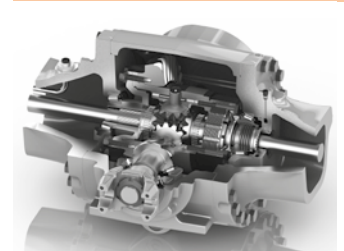

Differential hydraulic lock

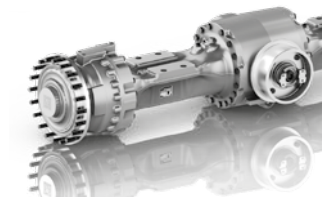

Heavy-duty axles



Protection+ warranty



Quick coupler



Attachments

Some of these options may be standard in some markets. Some of these options may not be available for certain markets. Please check with your local DOOSAN dealer for more information about availability or to adapt your machine to your application needs.

WORK EFFICIENCY MANAGEMENT

JOB SITE MANAGEMENT

PROACTIVE SERVICE

PREVENTIVE MAINTENANCE

OPERATION TREND

Total operation hours and operation hours by mode

FUEL EFFICIENCY*

Fuel level and fuel consumption

LOCATION

GPS and geo-fence

REPORTS

Operation report & utilization

WARNING & ALERT

Detect machine warnings, antenna disconnection, and geo/time fence

FILTER & OIL MANAGEMENT

Preventive maintenance by item replacement cycle

TELEMATICS TERMINAL

Terminal device is installed and connected to a machine to get machine data.

TELECOMMUNICATION

Doosan provides Dual mode (Mobile, Satellite) communication to maximize communication coverage.

DOOSANCONNECT WEB

Users can monitor machine status from DoosanCONNECT Web.

